

# Backscatter TriClamp Process Probe

## Applications:

- Interface detection
- Concentration measurement
- Product differentiation & identification
- Control & optimize CIP cycles

The Kemtrak backscatter TriClamp process probe is designed to accurately measure suspended solids directly in pipelines. The probe uses a standard DN25/1" TriClamp sanitary type process connection making it suitable for direct mounting on any size pipeline greater than DN50/2" diameter.

The dual fiber optic design of the immersion probe provides high resolution at low turbidity with excellent linearity all the way up to high concentrations when used with a Kemtrak NBP007 near-infrared backscatter photometer.

A unique benefit of the Kemtrak backscatter immersion probe is that it does not go blind at high sample concentrations. Other probes will stop working at 4 000 NTU/FNU (<1 wt% solids) after which the signal will decrease resulting in an erroneous and misleading output. The output of the Kemtrak probe will continue to increase with sample concentration ensuring a reliable measurement.

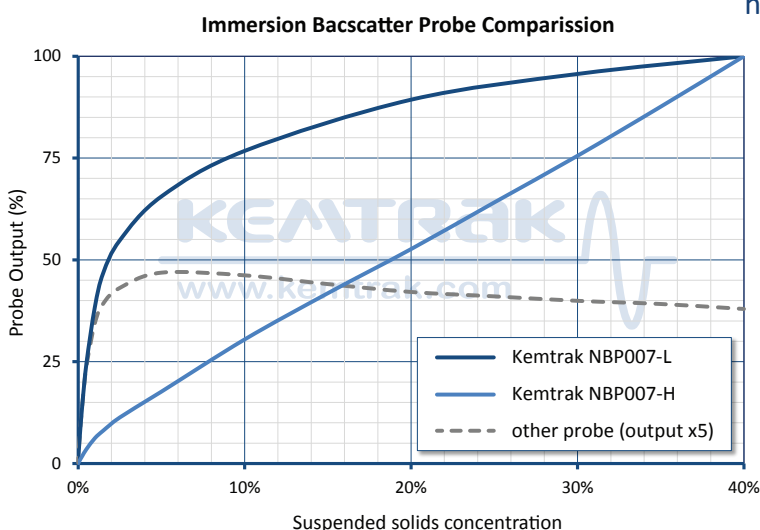

The backscatter probe is manufactured in 316L stainless steel with a robust scratch resistant sapphire window. The highly polished unbroken probe surface ensures freedom from fouling and suitability for sanitary applications.

The fiber optic immersion probe has no electronics that will be damaged by high temperature process streams or sterilization cycles and are well suited for both ordinary and hazardous area installation.

All Kemtrak products are designed to meet the most demanding application specifications and are made from the highest quality materials to ensure exceptionally long life and the highest reliability possible.

**KEATRak**

[www.kemtrak.com](http://www.kemtrak.com)

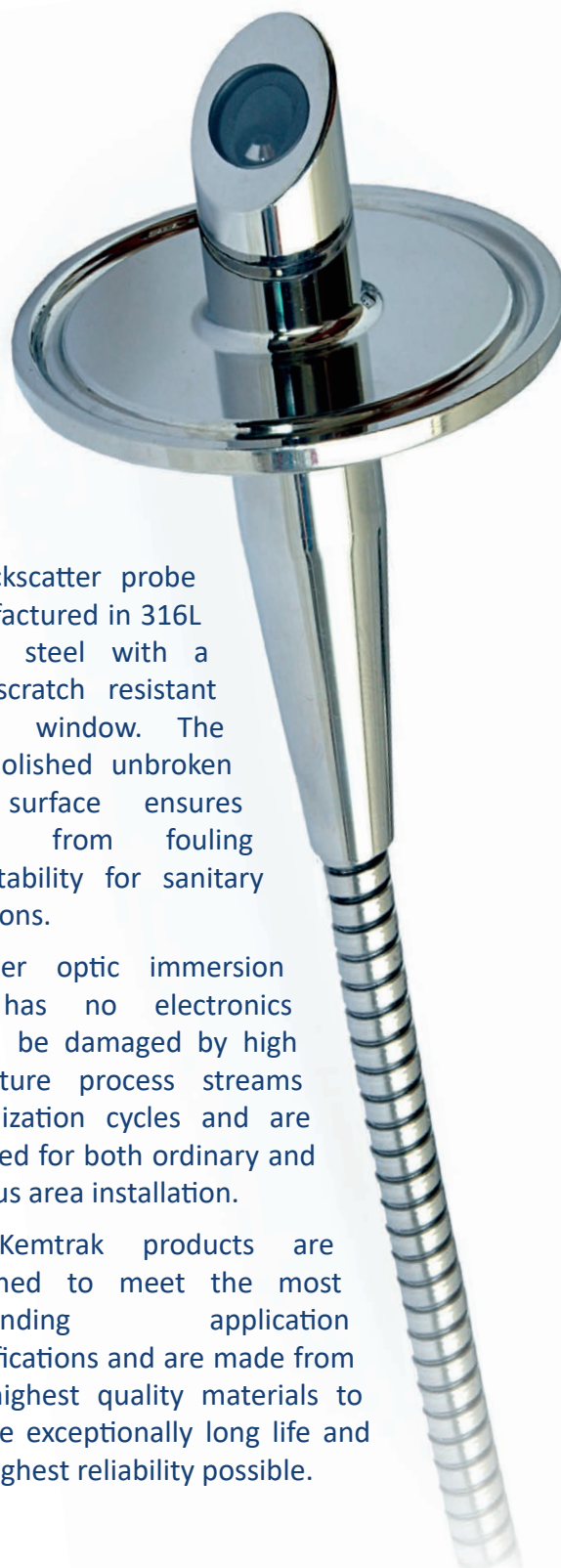



Compatible with  
DN 25, DN32, DN40  
1" and 1½" pipe clamp fittings

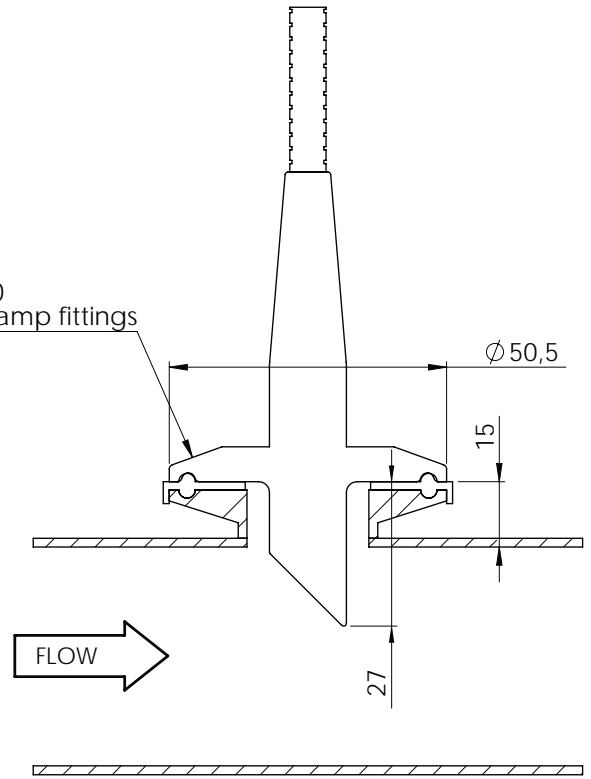

**Benefits:**

- 0.001% (ca. 10 NTU) to 100% total suspended solids
- Standard TriClamp type sanitary fitting (ISO 2852 & DIN 32676)
- Sapphire window is mounted from inside of probe and sealed using o-rings (no epoxy) - impossible to fall out in the process
- Suitable for ordinary and hazardous area installation

**Technical Data**  
**Backscatter TriClamp Probe**

**Measurement Range**

0.001% (ca. 10NTU) to 100% total suspended solids

**Manifold**

Sanitary Tri-Clamp® clamp type fitting  
ISO 2852 & DIN 32676  
Compatible with 50,5 +0/-0,19 mm outside diameter (DN25, DN32, DN40, 1" and 1½").

**Material**

Stainless Steel EN 1.4435 / 316L

**Window**

Sapphire

**Surface Finish**

Ra < 0.38 µm

**Elastomers**

FPM (FKM/Viton®), FFKM (Chemraz®/Kalrez®, FDA), EPDM (FDA)

**Operating Conditions**

Ambient & process temperatures up to 200°C (392°F)  
Process pressure from 10mbar to 25 bar (0,14 – 363 psi)  
Operating conditions subject to material and design in use

**Fibre Optic cable**

Silica core photonic fiber with Kevlar® reinforced flexible  
LZSH coated stainless steel jacket  
Fully-interlocked stainless steel conduit for use above 85°C (185°F)  
Terminated with SMA 905 connectors  
5m standard (16.4 ft)  
Lengths up to 20m (66 ft)

**Protection**

IP66 / EN 60529

**Recommended Controller**

Kemtrak NBP007 backscatter photometer



Kemtrak AB • SE 187 66 Stockholm • Sweden  
sales@kemtrak.com • www.kemtrak.com

*We reserve the right to make changes  
without prior notice*

Distributor

*Kemtrak is a leading manufacturer of fiber optic measuring and automation products for the process engineering industry. Kemtrak provides tailor made solutions to meet the needs of a wide range of industries including chemical, petrochemical & offshore, biotech, pharmaceutical, food & beverage, pulp and paper and water & environment. Kemtrak has trained representatives and support personnel globally and is certified according to ISO 9001:2015.*